

STAFIX™

B1 Battery Powered Energiser Installation and Operating Instructions

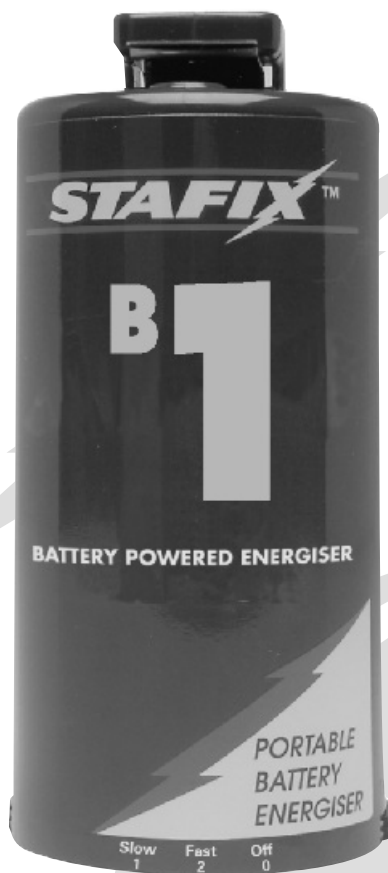

WARNING: Read all instructions

B1 12V

WARNING: Do not connect to mains operated equipment.

Build the fence (if required)

To optimise your new energiser's performance, ensure that your fence system is of a high standard, using high quality Stafix accessory products where appropriate.

Earthing

For optimum performance of your energiser a suitable earth system must be installed at least 10m (33ft) from other earth systems (ie. Telephone or mains/line power circuit). A galvanised metal rod driven into the ground 2 m (6 ft) will provide adequate earthing. Under poor earthing conditions (ie. dry or sandy soil) more rods may be necessary.

Recommended minimum number of earth rods	
Energiser model	Number of 2 m (6 ft) rods
B1	1

Energiser connection

Connect the energiser to the fence using one of these options;

Option A Simply depress the spring clip and hook directly onto fence wire.

Option B Connect the energiser to the fence wire using the yellow output lead.

Option C Hook the energiser onto the metal bracket of the fence reel then connect the energiser to the fence as with Option B.

Connect the energiser's earth clip to the earth rod.

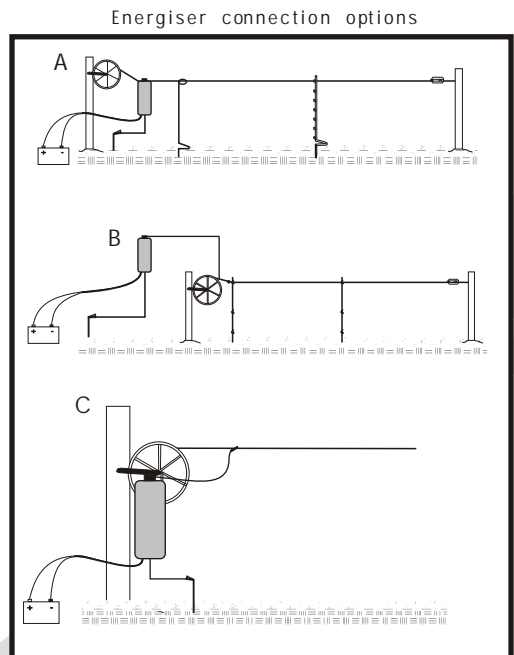

Connect the battery

A 12 V (100 Ah) wet cell deep cycle battery is recommended for best performance from your energiser, however any 12 V wet cell battery can be used.

Connect the battery supply cord Red clip to the positive (+) battery terminal and the battery supply cord Black clip to the negative (-) battery terminal.

Note: To avoid damage to your energiser from wet cell batteries ensure that the energiser is approximately 1m (3 ft) away from and not directly above, the battery.

Battery care

To optimise the expected total life of your battery:

- Avoid complete discharging (100% discharge) of your battery.
- If a battery is accidentally discharged completely, recharge it as soon as possible.
- Batteries should be charged prior to storage then recharged at regular intervals (every 8 weeks) during storage.
- Avoid high temperatures > 50 °C (120 °F) and keep naked flames and sparks away from battery when recharging. The battery should not be placed directly underneath the energiser.
- Check battery electrolyte level at every recharge and refill, preferably with deionized, distilled or rain water.

Battery life guide - for 80% discharge of battery

Energizer model	100 Ah battery		60 Ah battery	
	Fast pulse	Slow pulse	Fast pulse	Slow pulse
B1	30 days	60 days	18 days	35 days

Operation of the energiser

Turn the pulse speed switch to Slow (approx 2 seconds/pulse) or Fast (approx 1.2 seconds/pulse) as desired.

Hint: Use Fast setting for training animals that have not experienced electric fences before or for feral animal fences. Use Slow for normal running to conserve battery power.

The "Pulse" light will flash with each pulse, indicating the speed.

Solar instructions

Install the energiser on the underside of the Stafix solar panel so as to protect it from the weather. Read the installation and operating instructions supplied with the Stafix solar panel system.

Note: Do not power the energiser directly from a solar panel without using a 12 V external battery.

PLEASE SAVE THESE INSTRUCTIONS FOR FUTURE USE

Safety Points and Regulations

All energisers must comply with local standard requirements. These requirements may vary from country to country.

In areas prone to bush fires there may be a risk of fire caused by sparking from the fence. In high risk situations, if available, the Fence Low Output should be used, or the energiser should be turned off.

Barbed Wire should never be used for electric fencing.

Energisers should, if possible be installed inside a building in a position free from the risk of mechanical damage. If mounted outdoors they should be mounted on a substantial structure in a position free from risk of mechanical damage.

Avoid erecting a fence which runs parallel to or under power lines. Where this is unavoidable the crossing should be underneath the power lines and as near as possible at right angles to the lines.

If an electric fence has to be installed in the vicinity of an overhead power line, the vertical distance between any fence wire or connecting lead and the surface of the earth should not exceed 2 m.

Fence wiring should be installed so that it is well away from any telephone/telegraph line or radio aerial.

Each energiser should be connected to its own earth system and this should not be connected to any other earth system.

Do not connect more than one energiser to a single electric fence.

Do not connect the energiser simultaneously to a fence and to any other device such as a cattle trainer or poultry trainer, otherwise lightning striking your fence will be conducted to all other devices.

When an electric fence is installed where it might reasonably be expected to be touched by the public then warning signs must be attached. The warning sign must be at least 200 mm x 100 mm (8" x 4") in size and should be attached at intervals not exceeding 90 m (295 ft).



The sign should display the symbol as on the Stafix sign or the words "Electric Fence".

The inscription should be indelible and any lettering should have a height of at least 35 mm (1 1/3"). It is recommended that the basic colour of the sign be yellow with black inscription.

Electric fence energisers are not intended for use by young children or infirm persons. Do not allow young children to play with the energiser or the electric fence.

When the energiser is used to supply a system of conductors used for deterring birds from roosting on buildings, no conductor should be connected to earth. A switch should be installed to provide means of isolating the energiser from all poles of the supply and clear warning signs should be fitted at every point where a person may have ready access to the conductors. The notice should bear the words "LIVE WIRES" in block letters not less than 13 mm (1/2") high, the letters should be red on a white background and the size of each notice should be not less than 62 mm x 50 mm (2 1/2" x 2") overall.



Tru-Test Ltd
Auckland, New Zealand

www.tru-test.com